

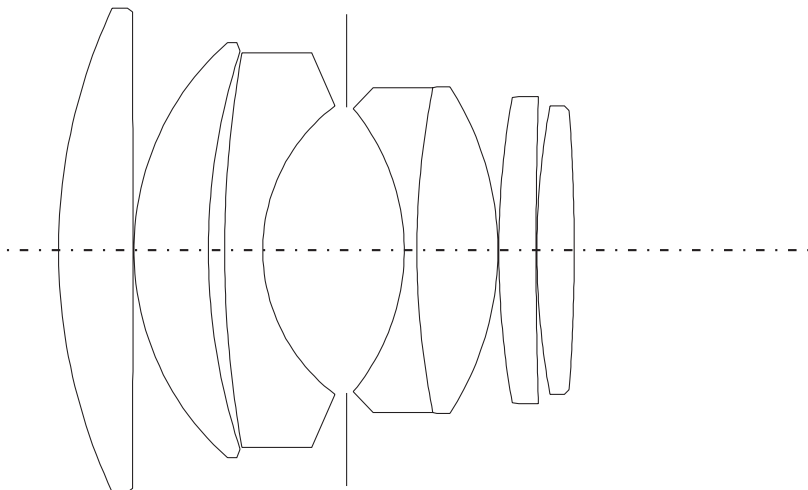

The speed of the Noctilux surpasses even that of the human eye. As the world's first production f/1 lens for 35 mm photography it is a milestone in the history of photography. Its outstanding contrast rendition provides a delicate separation of barely discernible color differences and an exact resolution of the finest details. Its maximal freedom of stray light and coma results in a practically flare-free reproduction of point sources of light. This lens makes a unique and fascinating pictorial expression possible. It is not only excellently suitable for photography at twilight, but also for nighttime photography without flash. The light of a candle is sufficient for beautifully clear pictorial results. Image details can be emphasized by taking advantage of the very shallow depth of field at full aperture. The contours in the unsharp areas of such pictures dissolve in a nearly abstract form and color aesthetic.

— Lens shape





— Engineering drawing

Technical Data

Angle of view (diagonal, horizontal, vertical)	47°, 40°, 27°
Optical design	Number of elements / groups: 7 / 6 Focal length: 52.4 mm Entrance pupil: 42.9 mm (related to the first lens surface in light direction) Focusing range: 1 m to Infinity
Distance setting	Scale: combined meter/feet-increments Smallest object field: 410 mm x 615 mm Highest reproduction ratio: 1:17
Diaphragm	Setting / Type: with clickstops (including half values), manual diaphragm Smallest aperture: f/16
Bayonet	Leica M quick-change bayonet
Filter (type)	internal thread for screw-in type filters E 60
Lens hood	built-in, telescopic
Dimensions and weight	Length: 62 mm Largest diameter: 69 mm Weight: approx. 630 g

— MTF graphs

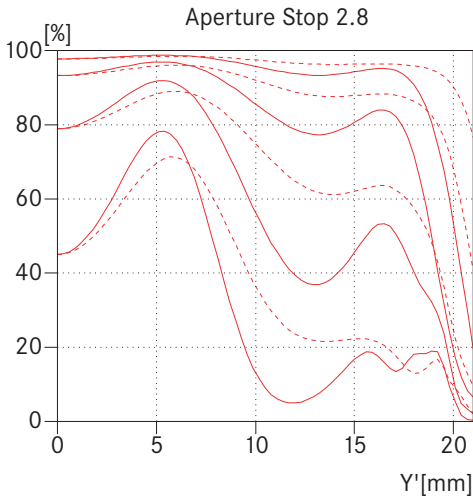
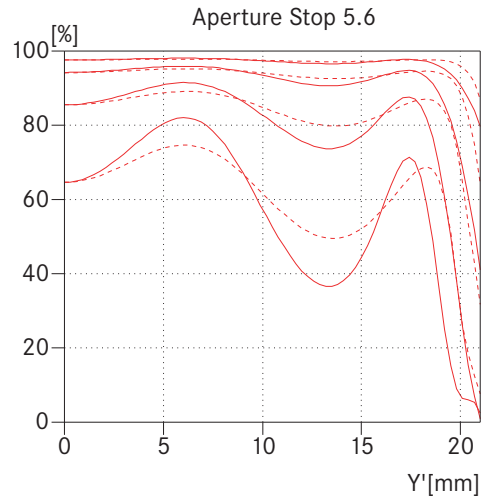
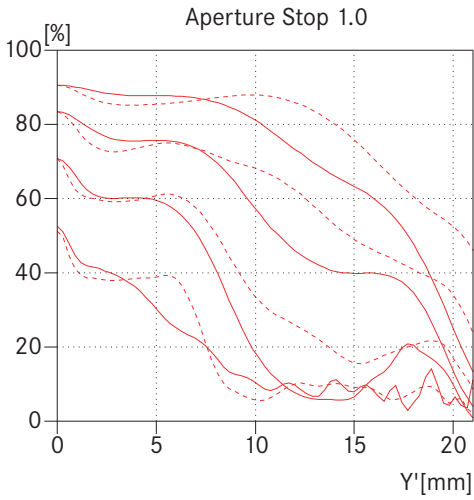

The MTF is indicated both at full aperture and at f/5.6 at long taking distances (infinity). Shown is the contrast in percentage for 5, 10, 20 and 40 lp/mm across the height of the 35 mm film format, for tangential (dotted line) and sagittal (solid line) structures, in white light. The 5 and 10 lp/mm will give an indication regarding the contrast ratio for large object structures. The 20 and 40 lp/mm records the resolution of finer and finest object structures.

- sagittal structures
- - - tangential structures

— Distortion

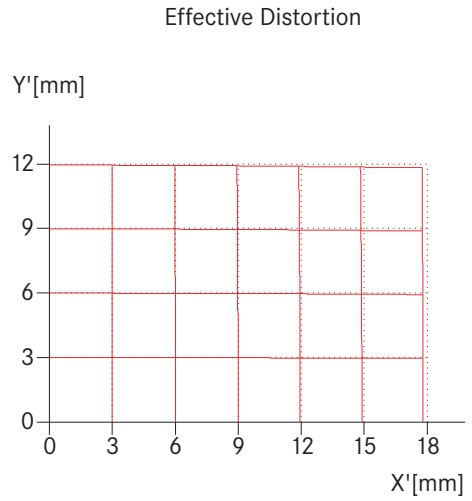
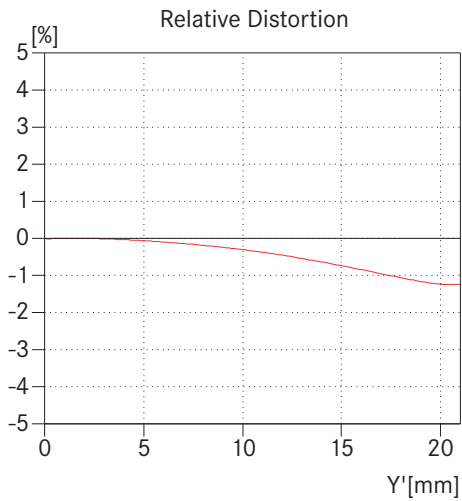

— Vignetting

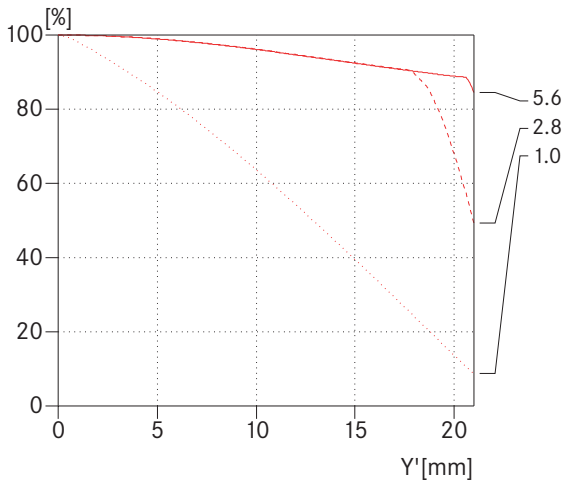

Distortion is the deviation of the real image height (in the picture) from the ideal image height. The relative distortion is the percentage deviation. The ideal image height results from the object height and the magnification. The image height of 21.6mm is the radial distance between the edge and the middle of the image field for the format 24mm x 36mm. The graph of the effective distortion illustrates the appearance of straight horizontal and vertical lines in the picture.

Vignetting is a continuous decrease of the illumination to the edges of the image field. The graph shows the percentage lost of illumination over the image height. 100% means no vignetting.

- sagittal structures
- - - tangential structures



— Depth of field table

1	0,989 - 1,012	0,985 - 1,016	0,978 - 1,023	0,970 - 1,032	0,958 - 1,046	0,942 - 1,066	0,919 - 1,097	0,892 - 1,139	0,851 - 1,216	1/17,3
1,2	1,183 - 1,217	1,178 - 1,223	1,169 - 1,233	1,157 - 1,247	1,139 - 1,268	1,116 - 1,298	1,084 - 1,345	1,046 - 1,410	0,989 - 1,532	1/21,1
1,5	1,474 - 1,527	1,465 - 1,537	1,451 - 1,553	1,432 - 1,575	1,404 - 1,610	1,369 - 1,659	1,320 - 1,738	1,264 - 1,849	1,180 - 2,069	1/26,9
2	1,954 - 2,049	1,938 - 2,067	1,912 - 2,097	1,879 - 2,138	1,831 - 2,204	1,772 - 2,298	1,689 - 2,455	1,597 - 2,685	1,464 - 3,185	1/36,4
3	2,896 - 3,112	2,860 - 3,155	2,803 - 3,227	2,732 - 3,327	2,631 - 3,491	2,508 - 3,736	2,344 - 4,178	2,167 - 4,903	1,926 - 6,912	1/55,5
5	4,715 - 5,322	4,618 - 5,451	4,472 - 5,671	4,291 - 5,994	4,045 - 6,553	3,758 - 7,486	3,398 - 9,523	3,035 - 14,45	2,578 - 107,5	1/93,7
10	8,915 - 11,39	8,571 - 12,00	8,077 - 13,13	7,500 - 15,02	6,775 - 19,15	6,002 - 30,25	5,127 - 235	4,338 - ∞	3,456 - ∞	1/189
∞	81,64 - ∞	59,52 - ∞	41,66 - ∞	29,76 - ∞	20,84 - ∞	14,90 - ∞	10,44 - ∞	7,603 - ∞	5,240 - ∞	1/∞

